

# Series N Actuators

1-1/8" to 4" bore sizes  
NFPA Interchangeable



Cylinders rated to 250 PSI air,  
400 PSI hydraulic (non-shock).

Designed for non-lube service.  
Switches available on all bore sizes.

## Technical data

Medium:  
Filtered compressed air to  
250 psi  
(for hydraulic service  
consult factory.)

Operating Temperatures:  
-20°F to 200°F  
(-29°C to 93°C)

Operating Pressure:  
250 psig (17.2 bar)

1-1/8" Bore pressure rating: 150 psi

Bore Sizes:

1-1/8", 1-1/2", 2", 2-1/2", 3-1/4", 4"

Materials:

Head and end caps - anodized 6061-T6  
aluminum

Tube: 6063-T832 aluminum, clear  
anodized O.D., hard coat anodized I.D.

Piston Rod: C1141 hard chrome plated  
steel

Piston: 2011-T451 aluminum

Rod Bearings: G2 Durabar cast iron,  
teflon coated

Seals: carboxylated nitrile

Tie Rods: 12L14 steel

## Options selector

N C 04 J - E 0 2 - A M B 0 0

Series	
Series N	N
Series Q Electroless Nickel	Q

Bore	Single rod end	Double rod end*
1-1/8"	B	P
1-1/2"	C	Q
2"	D	R
2-1/2"	E	S
3-1/4"	F	T
4"	G	U

\* Double Rod End has two Piston Rods on one end and one Piston Rod on opposite end.

Strokes in inches	Substitute
0" Stroke	00
1" Stroke	01
2" Stroke	02
3" Stroke	03
4" Stroke	04
5" Stroke	05
6" Stroke	06
...	...
30" Stroke	30
Special	xx

Fractional Increments of Stroke			
0"	A	1/2"	J
1/16"	B	9/16"	K
1/8"	C	5/8"	M
3/16"	D	11/16"	N
1/4"	E	3/4"	P
5/16"	F	13/16"	R
3/8"	G	7/8"	S
7/16"	H	15/16"	T
X	Special		

Rod Axis	
Horizontal Rod Axis	E
Vertical Rod Axis	N
No Tooling Plate - Horizontal Rod	A
No Tooling Plate - Vertical Rod	B
Blank Rod End - Horizontal Rod*	C
Blank Rod End - Vertical Rod*	D
Special	X

\* Does not include tooling plate  
Note: Double rod is not available with oversize rear rod on 1-1/2" bore.

Options	
No Options	0
Metal Rod Scraper	M
Air/Oil Piston	P
Double Rod W/OS Cap Rod	R
Stainless Piston Rods	S
Viton Seals	V
Special	X

Magnetic Option	
No Magnet	0
Magnetic Piston	M

Design Level	
	B

Cushions†				
Needle Position	1	2**	3	4
No Cushions	A			
Head Only	B	C	D	E
Cap Only	G	H	J	K
Head and Cap	N	M	P	R
Special	X			

†Cushions not available on 1-1/8" Bore.

\*\*Standard position

Ports				
Position	1**	2	3	4
Standard	A	B	C	D
Special	X			

\*\*Standard position

Mounting Options			
01 No Mounts (MX0)	07 Det. Clevis (MP2)		
02 Bottom Tap (MS4)	18 Det. Eye (MP4)		
04 Front Flange (MF1)	20 Base Bar		
05 Rear Flange (MF2)	XX Special		

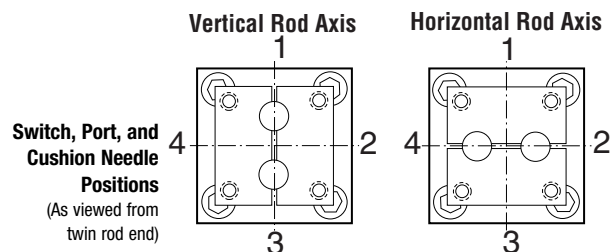

# Series N Actuators

1-1/8" to 4" bore sizes

## Basic Actuator 01 (MX0)

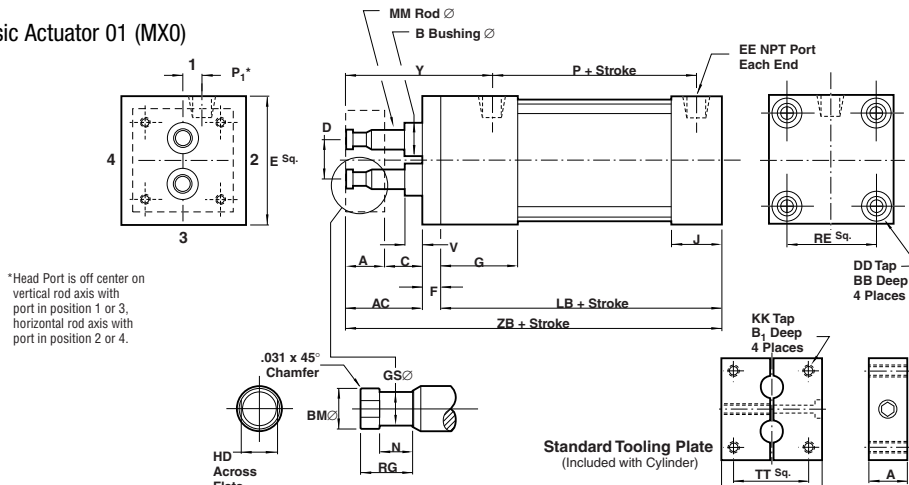

Standard Tooling Plate  
(Included with Cylinder)

Bore	A	AC	B	B1	BB	BM	C	D	DD	E	EE	F	G	GS
1-1/8"	0.625	1.25	N/A	0.5	0.188	0.27	0.625	0.627	10 - 32	1.5	1/8	0.25	.875	0.19
1-1/2"	0.625	1.5	0.59	Thru	0.312	0.33	0.875	0.75	1/4 - 28	2	1/4	0.375	1.5	0.25
2"	0.75	1.5	0.9	Thru	0.312	0.55	0.75	1.052	5/16 - 24	2.5	1/4	0.375	1.5	0.5
2-1/2"	0.75	1.75	0.9	Thru	0.312	0.55	1	1.398	5/16 - 24	3	1/4	0.375	1.5	0.5
3-1/4"	1.25	1.75	1.498	Thru	0.437	0.9	0.5	2	3/8 - 24	3.75	3/8	0.625	1.75	0.75
4"	1.25	1.75	1.498	Thru	0.437	0.9	0.5	2.36	3/8 - 24	4.5	3/8	0.625	1.75	0.75

Bore	HD	J	KK	LB	MM	N	P	P1	RE	RG	TT	TZ	V	Y	ZB
1-1/8"	0.25	0.625	6 - 32	2.25	0.312	0.4	1.469	0.241	1.125	0.58	0.75	1.25	N/A	2.031	3.75
1-1/2"	0.312	1	10 - 32	3.625	0.375	0.4	2.125	0.303	1.428	0.58	1.125	1.5	0.25	2.875	5.5
2"	0.5	1	1/4 - 28	3.625	0.625	0.526	2.125	0.48	1.84	0.705	1.43	2	0.25	2.875	5.5
2-1/2"	0.5	1	5/16 - 24	3.75	0.625	0.526	2.25	0.635	2.192	0.705	1.84	2.5	0.25	3.125	5.875
3-1/4"	0.812	1.25	3/8 - 24	4.25	1	0.784	2.625	0.845	2.758	1.205	1.79	3.25	0.25	3.437	6.625
4"	0.812	1.25	3/8 - 24	4.25	1	0.784	2.625	0.875	3.323	1.205	3.44	4	0.25	3.437	6.625

## Cylinder with 20 (not NFPA) Base Bar

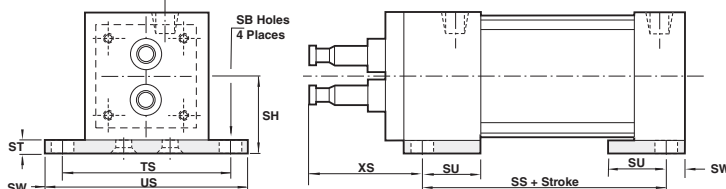

Bore	F	G	LB	SB	SS	ST	SU	SW	TS	US	XS
1-1/8"	0.25	1	2.25	0.203	1.75	0.25	0.75	0.25	1.875	2.375	1.75
1-1/2"	0.375	1.5	3.625	0.437	2.875	0.25	1.125	0.375	2.75	3.5	2.25
2"	0.375	1.5	3.625	0.437	2.875	0.25	1.125	0.375	3.25	4.0	2.25
2-1/2"	0.375	1.5	3.75	0.437	3	0.375	1.125	0.375	3.75	4.5	2.5
3-1/4"	0.625	1.75	4.25	0.563	3.25	0.5	1.25	0.5	4.75	5.75	2.875
4"	0.625	1.75	4.25	0.563	3.25	0.5	1.25	0.5	5.5	6.5	2.875

## Cylinder with 02 Bottom Tap

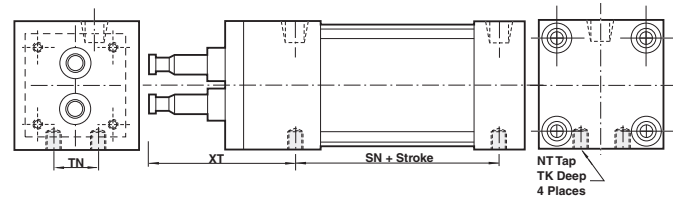

Bore	NT	SN	TK	TN	XT
1-1/8"	10 - 32	1.5	0.25	0.5	2
1-1/2"	1/4 - 20	2.25	0.375	0.625	2.812
2"	5/16 - 18	2.25	0.375	0.875	2.812
2-1/2"	3/8 - 16	2.375	0.625	1.25	3.063
3-1/4"	1/2 - 13	2.625	0.625	1.5	3.437
4"	1/2 - 13	2.625	0.75	2.063	3.437

## Cylinder with 04 (MF1) Front Flange

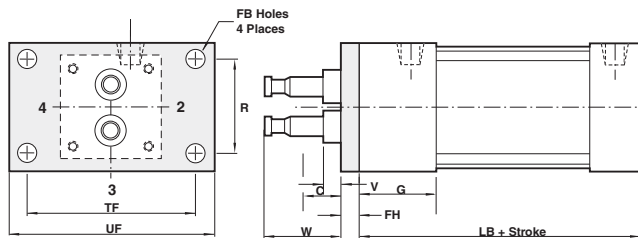

Bore	C	FB	FH	R	TF	UF	W
1-1/8"	0.625	0.219	0.25	1	2	2.5	1.25
1-1/2"	0.875	0.312	0.375	1.43	2.75	3.75	1.5
2"	0.75	0.375	0.375	1.84	3.375	4.125	1.5
2-1/2"	1	0.375	0.375	2.19	3.875	4.625	1.75
3-1/4"	0.5	0.437	0.625	2.76	4.688	5.5	1.75
4"	0.5	0.437	0.625	3.32	5.437	6.25	1.75

## Cylinder with 05 (MF2) Front Flange

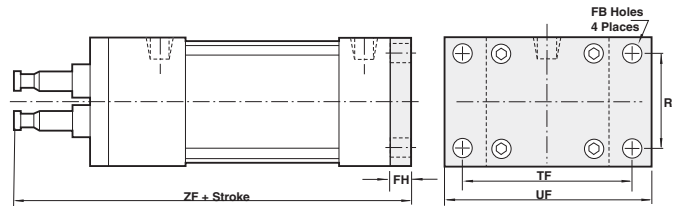

Bore	FB	FH	TF	UF	ZF
1-1/8"	0.219	0.25	2	2.5	4
1-1/2"	0.312	0.375	2.75	3.75	5.875
2"	0.375	0.375	3.375	4.125	5.875
2-1/2"	0.375	0.375	3.875	4.625	6.25
3-1/4"	0.437	0.625	4.688	5.5	7.25
4"	0.437	0.625	5.437	6.25	7.25

# Series N Actuators

1-1/8" to 4" bore sizes

Cylinder with 07 (MP2) Detachable Clevis

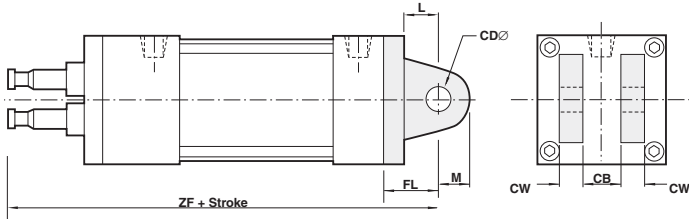

Bore	CB	CD	CW	FL	L	M
1-1/8"	0.375	0.375	0.25	1.125	0.625	0.375
1-1/2"	0.75	0.5	0.5	1.125	0.75	0.625
2"	0.75	0.5	0.5	1.125	0.75	0.625
2-1/2"	0.75	0.5	0.5	1.125	0.75	0.625
3-1/4"	1.25	0.75	0.625	1.875	1.25	0.875
4"	1.25	0.75	0.625	1.875	1.25	0.875

Cylinder with 18 (MP4) Detachable Clevis

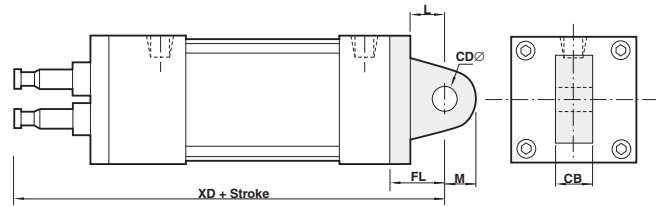

Bore	CB	CD	FL	L	M	XD
1-1/8"	0.375	0.375	1.125	0.625	0.375	4.875
1-1/2"	0.75	0.5	1.125	0.75	0.625	6.625
2"	0.75	0.5	1.125	0.75	0.625	6.625
2-1/2"	0.75	0.5	1.125	0.75	0.625	7
3-1/4"	1.25	0.75	1.875	1.25	0.875	8.375
4"	1.25	0.75	1.875	1.25	0.875	8.375

Double rod End Cylinder

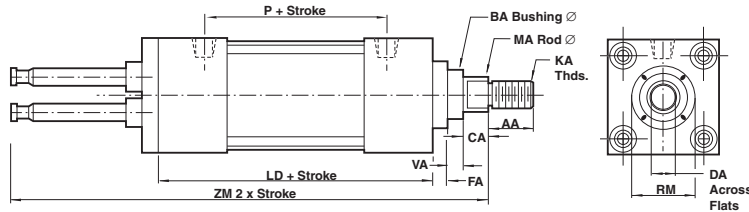

Bore	AA	BA	CA	DA	FA	KA	LD	MA	P	RM	VA	ZM	
1-1/8"	Standard	0.625	N/A	0.25	0.312	0.125	3/8 - 24	‡2.875	0.375	‡1.844	0.75	N/A	‡4.625
	Oversize	0.75	N/A	0.25	0.437		1/2 - 20		0.5		1.00	N/A	
1-1/2"	Standard	0.75	1.125	0.375	0.5	0.375	1/2 - 20	4.125	0.625	2.125	2.00	0.25	7.00
	Oversize	1.125	1.4	0.5	0.812		3/4 - 16		1.00		2.00	0.5	
2"	Standard	0.75	1.125	0.375	0.5	0.375	1/2 - 20	4.125	0.625	2.125	2.00	0.25	7.00
	Oversize	1.125	1.5	0.5	0.812		3/4 - 16		1.00		2.50	0.5	
2-1/2"	Standard	.75	1.125	0.375	0.5	0.375	1/2 - 20	4.25	0.625	2.25	2.00	0.25	7.35
	Oversize	1.125	1.5	0.5	0.812		3/4 - 16		1.00		3.00	0.5	
3-1/4"	Standard	1.125	1.5	0.5	0.812	0.625	3/4 - 16	4.75	1.00	2.65	2.625	0.25	8.50
	Oversize	1.625	2	0.625	1.125		1 - 14		1.375		3.375	0.375	
4"	Standard	1.125	1.5	0.5	0.812	0.625	3/4 - 16	4.75	1.00	2.625	2.625	0.25	8.5
	Oversize	1.625	2	0.625	1.125		1 - 14		1.375		3.375	0.375	

\*Note: 1-1/8" bore overall body is 3/8" longer than our standard Series "C" Double Rod End Cylinder.

Double Rod End w/20 (not NFPA) base bar

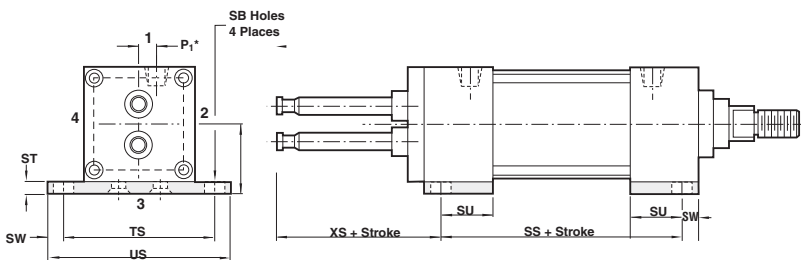

Bore	F	SB	SS	ST	SU	SW	TS	US	XS
1-1/8"	0.25	0.203	2.25	0.25	0.75	0.25	1.875	2.375	1.75
1-1/2"	0.375	0.437	3.375	0.25	1.125	0.375	2.75	3.5	2.25
2"	0.375	0.437	3.375	0.25	1.125	0.375	3.25	4	2.25
2-1/2"	0.375	0.437	3.5	0.375	1.125	0.375	3.75	4.5	2.25
3-1/4"	0.625	0.563	3.75	0.5	1.25	0.5	4.75	5.75	2.875
4"	0.625	0.563	3.75	0.5	1.25	0.5	5.5	6.5	2.875

NFPA Clevis Bracket Dimensions

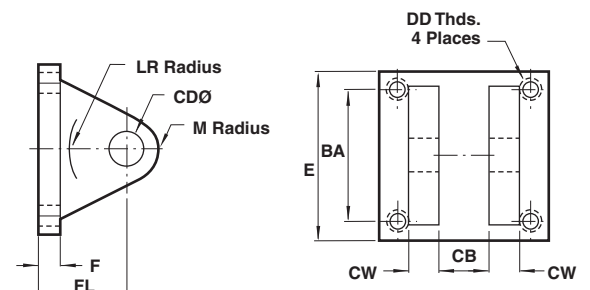

	BA	CB	CD	CW	DD	E	F	FL	LR	M
C-91-03A	1.625	.750	.50	.50	3/8-24	2.50	.375	1.125	.750	.500
C-91-065A	2.562	1.250	.750	.625	1/2-20	3.500	.625	1.875	1.250	.812
C-91-12A	3.250	1.500	1.000	.750	5/8-18	4.500	.750	2.250	1.500	1.000

# Series N Actuators

1-1/8" to 4" bore sizes

## Double Rod End w/04 (MF1) Front Flange

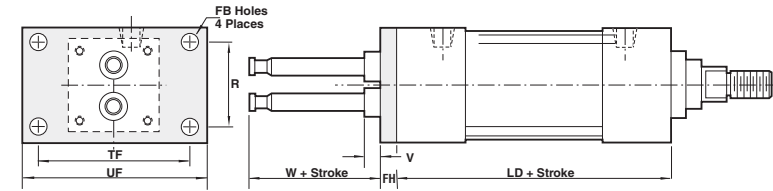

Bore	C	FB	FH	TF	TZ	UF	V	W
1-1/8"	0.625	0.219	0.250	2	1.25	2.5	N/A	1.25
1-1/2"	0.875	0.312	0.375	2.75	1.5	3.75	0.25	1.5
2"	0.75	0.375	0.375	3.375	2	4.125	0.25	1.5
2-1/2"	1	0.375	0.375	3.875	2.5	4.625	0.25	1.75
3-1/4"	0.5	0.437	0.625	4.688	3.25	5.5	0.25	1.75
4"	0.5	0.437	0.625	5.437	4	6.25	0.25	1.75

## NFPA Eye Bracket Dimensions

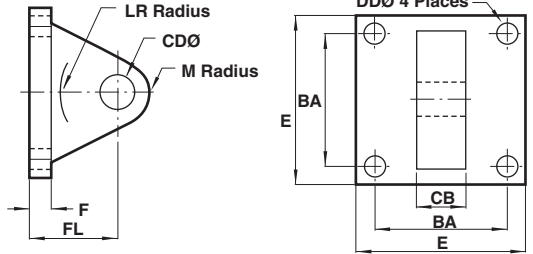

Bore	BA	CB	CD	DD	E	F	FL	LR	M
C-89-03A	1.625	.750	.500	.406	2.500	.375	1.125	.750	.50
C-89-065A	2.562	1.250	.750	.531	3.500	.625	1.875	1.250	.750
C-89-12A	3.250	1.500	1.000	.656	4.500	.750	2.250	1.500	1.000

## Double Rod End w/02 (MS4) bottom tap

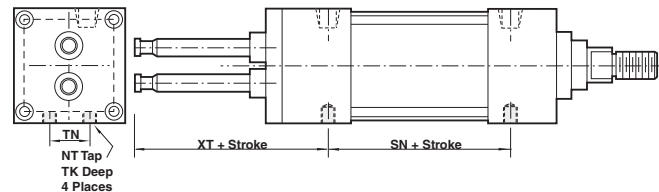

Bore	NT	SN	TK	TN	XT
1-1/8"	10 - 32	1.875	0.25	0.5	2
1-1/2"	1/4 - 20	2.25	0.375	0.625	2.812
2"	5/16 - 18	2.25	0.375	0.875	2.812
2-1/2"	3/8 - 16	2.375	0.625	1.25	3.063
3-1/4"	1/2 - 13	2.625	0.625	1.5	3.437
4"	1/2 - 13	2.625	0.75	2.063	3.437

## Modular Adaptor Plate Dimensions

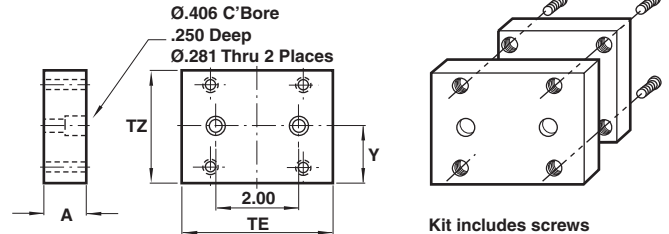

Bore	A	TE	TZ	Y
NB-172-225K (1-1/8")	0.625	3.00	1.25	0.625
NB-172-03K (1-1/2")	0.625	3.00	1.50	0.75
NB-172-04K (2")	0.625	3.00	2.00	1.00
NB-172-05K (2-1/2")	0.625	3.00	2.50	1.25

## 1-1/8" Bore Eye & Clevis Bracket Dimensions

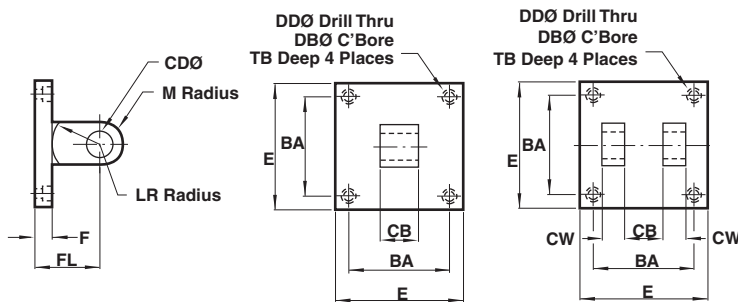

	BA	CB	CD	CW	DB	DD	E	F	FL	LA	M	TB
W-89-225K Eye	1.125	.375	.375	—	.328	.203	1.500	.500	1.125	.625	.375	.312
W-91-225K Clevis	1.150	.375	.375	.250	.328	.203	1.500	.500	1.125	.625	.375	.312

## Rod Eye Dimensions

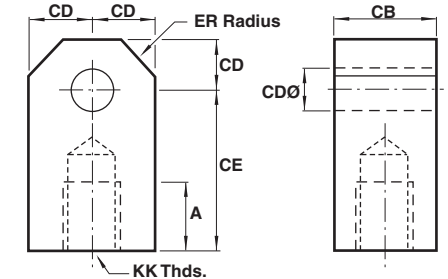

	CB	CD	CE	ER	KK
C-97-03	.750	.500	1.500	.562	1/2-20
C-97-065	1.250	.750	2.062	.937	3/4-16
C-97-12	1.500	1.000	2.812	1.125	1-14

# Series N Actuators

1-1/8" to 4" bore sizes

## Rod Clevis Dimensions

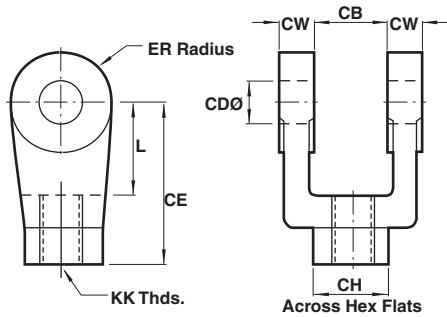

	CB	CD	CE	CH	CW	ER	KK	L
C-92-03	.750	.500	1.500	1.000	.500	.500	1/2-20	.750
C-92-065	1.250	.750	2.375	1.250	.625	.750	3/4-16	1.250
C-92-12	1.500	1.000	3.125	1.500	.750	1.000	1-14	1.500

## NFPA Pin Dimensions

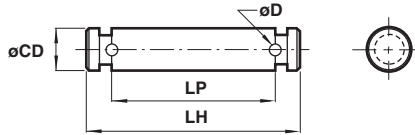

	CD	LH	LP
C-96-03A	.500	2.219	1.875
C-96-065A	.750	3.125	2.750
C-96-12A	1.000	3.750	3.250

## Pilot Adaptor Plate Dimensions

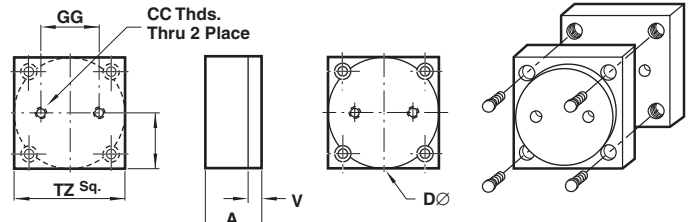

Kit includes screws

Bore	A	CC	D	GG	TZ	V	Y
NB-171-225K (1-1/8")	.625	1/4-20	1.260	.750	1.25	.160	.625
NB-171-03K (1-1/2")	.625	5/16-18	1.575	.860	1.500	.160	.750
NB-171-04K(2")	.625	5/16-18	1.969	1.180	2.000	.200	1.000
NB-171-05K (2-1/2")	.625	3/8-16	2.480	1.500	2.500	.200	1.250
NB-171-065K (3/4")	.875	1/2-13	3.150	1.970	3.250	.200	1.625
NB-171-08K (4")	.875	1/2-13	3.937	2.760	4.000	.200	2.000

## Standard Pin Dimensions

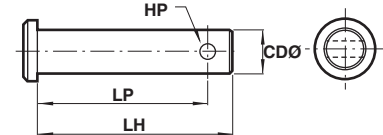

	CD	HP	LH	LP
C-96-225	.375	.156	1.250	1.032
C-96-03	.500	.156	2.250	2.093
C-96-065	.750	.156	3.000	2.843
C-96-12	1.000	.203	3.500	3.297

## The finest materials for each component!

**1 Piston Seals:** Lip-type carboxylated nitrile incorporating Teflon® and other non-lube additives as integral parts of the compound. Extremely smooth stroke performance and “no lube added” operation results from reduced friction.

**2 Piston:** Solid aluminum alloy, light-weight for low inertia, yet strong.

**3 Head/Cap:** Precision machined from (6061-T6) solid aluminum bar, anodized for corrosion resistance.

**4 Rod Wiper:** Lip-type urethane aggressively wipes foreign material from piston rod.

**5 Rod Seals:** Rounded lip-type carboxylated nitrile incorporating Teflon® and other non-lube additives as integral parts of the compound. Extremely smooth stroke performance and “no lube added” operation results from reduced friction. Rod Seal is pressure-energized and wear-compensating.

**6 Piston Rods:** High-strength, hard-chrome plated, ground and polished steel.

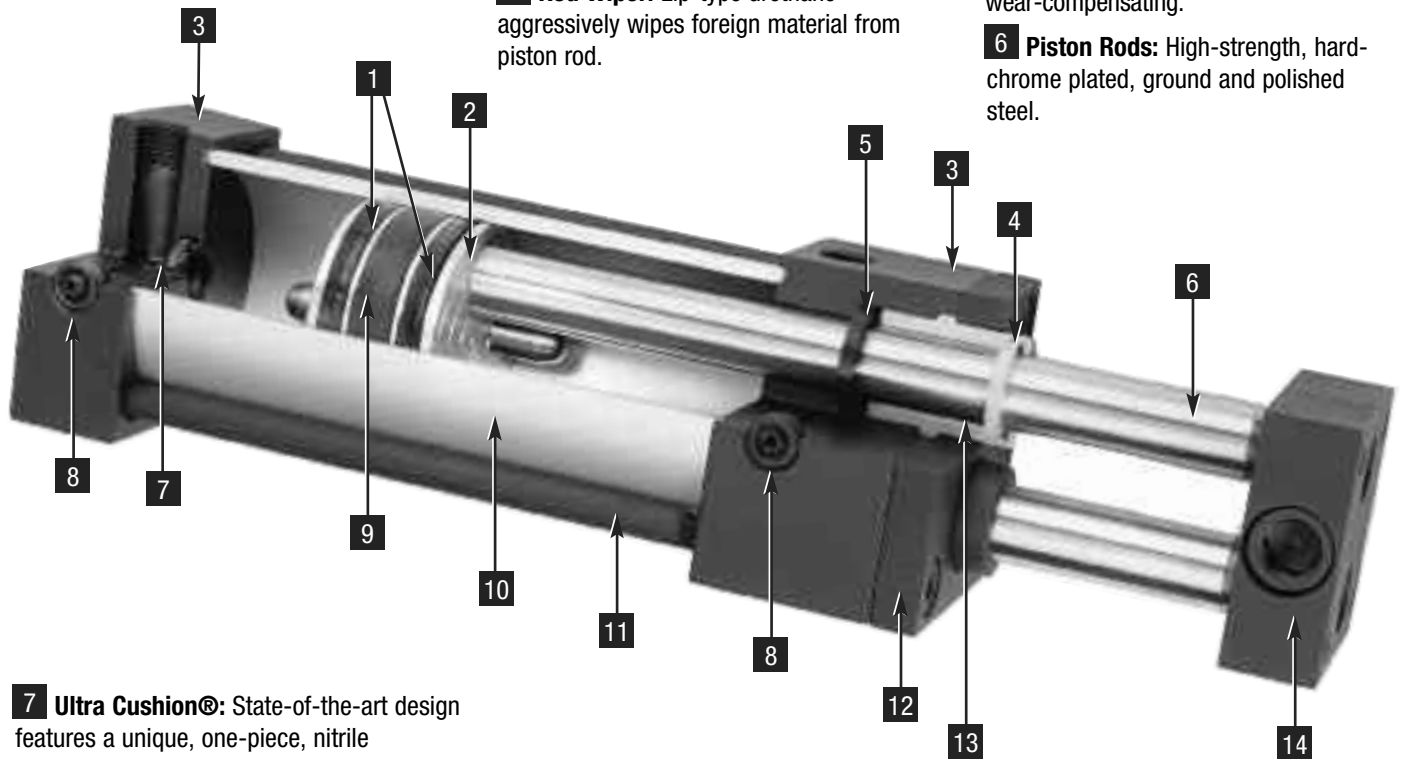

**7 Ultra Cushion®:** State-of-the-art design features a unique, one-piece, nitrile compound seal, captured within a precision machined groove. Linear and radial “float” of cushion seal eliminates misalignment. Ultra Cushions provide exceptionally fast “out of cushion” stroke reversal. (Head and Cap Cushions are optional.)

**8 Adjustable Captive Cushion Needle**

**9 Wear Strip:** Teflon® and graphite composition for minimum friction, maximum wear and side load resistance. (Magnetic band under wear strip optional.)

**10 Tube:** 6063-T832 aluminum alloy ideally suited for air service. Tube is clear anodized on the O.D. and “hard anodic coated” on the I.D. resulting in a smooth, file-hard (60RC), corrosion-resistant and score-resistant surface finish.

**11 Tie Rods:** High-strength steel maintains compression on tube end seals.

**12 Retainer:** High-strength steel is used to retain rod bearings.

**13 Rod Bearings:** Machined from durable, close-grained cast iron, then completely coated with Teflon® to insure permanent lubrication and corrosion resistance.

**14 Tooling Plate:** Machined from solid steel and notched for secure attachment. Modular and pilot adaptor plates are available to add to the tooling plate mounting. (Use of modular and pilot adapter plates adds to overall length.)

### Series Q

Series Q cylinders are designed for corrosive environments. They are identical to the Series N in design, function, and dimensions, but have electroless nickel plating and stainless steel components to create significant resistance to corrosion.

#### Features:

Head, cap, tube, bushings, front plate, mounts, tooling plate, tie rod nuts, and screws are plated with electroless nickel to a minimum thickness of .0005".

Piston rod, tie rods, and cushion needles are made from 300 series stainless steel.