

# PTH Filter/Regulator-Lubricator Combination Units

## 07 Series

### Compact design

Filter removes liquids and solid particles down to 5 µm

Push to lock adjusting knob with tamper resistant option

Micro-Fog lubricator provides air line lubrication to one or more air driven tools or other devices

Nearly constant oil density output with varying air flow

### Fluid:

Compressed air

### Maximum pressure

Transparent bowl: 150 psig (10 bar)

Metal bowl: 250 psig (17 bar)

### Operating temperature\*

Transparent bowl: 0° to 125°F (-20° to 50°C)

Metal bowl: 0° to 150°F (-20° to 65°C)

\* Air supply must be dry enough to avoid ice formation at temperatures below 35°F (2°C)

Typical flow at 100 psig (7 bar) inlet pressure, 90 psig (6.3 bar) set pressure and a droop of 15 psig (1 bar) from set:

1/8" ports: 10 scfm (5 dm<sup>3</sup>/s)

1/4" ports: 14 scfm (7 dm<sup>3</sup>/s)

### Drain connection:

1/8" male pipe

### Filter/Regulator

#### Particle removal:

5 µm or 40 µm. Within ISO 8573-1, Class 3 and Class 5

#### Gauge ports:

1/8" PTF with PTF main ports

1/8" ISO Rc with ISO Rc main ports

1/8" ISO Rc with ISO G main ports

#### Automatic drain operation:

Spitter type drain operates momentarily when a rapid change in air flow occurs or when the supply pressure is reduced.

### Lubricator

Start point (i.e., minimum flow required for lubricator operation): 0.5 scfm (0.24 dm<sup>3</sup>/s) at 90 psig (6.3 bar) inlet pressure

#### Nominal bowl capacity:

1 fluid ounce (31 ml)

### Materials

Bodies: Zinc



### Ordering Information

Models listed include PTF threads, transparent bowls, filter/regulator with relieving diaphragm, automatic drain, 5 µm element, 5 to 100 psig (0.3 to 7 bar) outlet pressure adjustment range\*, gauge, and microfog lubricator .

Port Size	Model Number	Weight lbs (kg)
1/8"	PTH-100-A1AA	0.87 (40)
1/4"	PTH-200-A1AA	0.87 (40)

\* Outlet pressure can be adjusted to pressures in excess of, and less than, those specified. Do not use these units to control pressures outside of the specified ranges.

Filter/Regulator bonnet: Acetal

Filter/Regulator valve seat: Acetal

Bowls

Transparent: Polycarbonate

Metal: Zinc

Lubricator sight-feed dome: Transparent nylon

Filter element: Sintered polypropylene

Elastomers: Nitrile

# PTH Filter/Regulator-Lubricator Combination Units

07 Series

## Alternative Models

Port Size	Substitute
1/8"	1
1/4"	2

Filter/Regulator	Outlet Pressure		Relief	Gauge	Substitute
	bar	psig			
Transparent	5 to 100	0.3 to 7	Relieving	With	00
Transparent	5 to 100	0.3 to 7	Relieving	Without	01
Metal / no sight glass	5 to 100	0.3 to 7	Relieving	With	40
Metal / no sight glass	5 to 100	0.3 to 7	Relieving	Without	41

Lubricator Reservoir	Substitute
Transparent with drain	A
Metal with drain	M

  

Filter/Regulator Element	Substitute
5 μm	1
40 μm	3

Filter/Regulator Drain	Substitute
Automatic	A
Manual	M

\* Outlet pressure can be adjusted to pressures in excess of, and less than, those specified. Do not use these units to control pressures outside of the specified ranges.

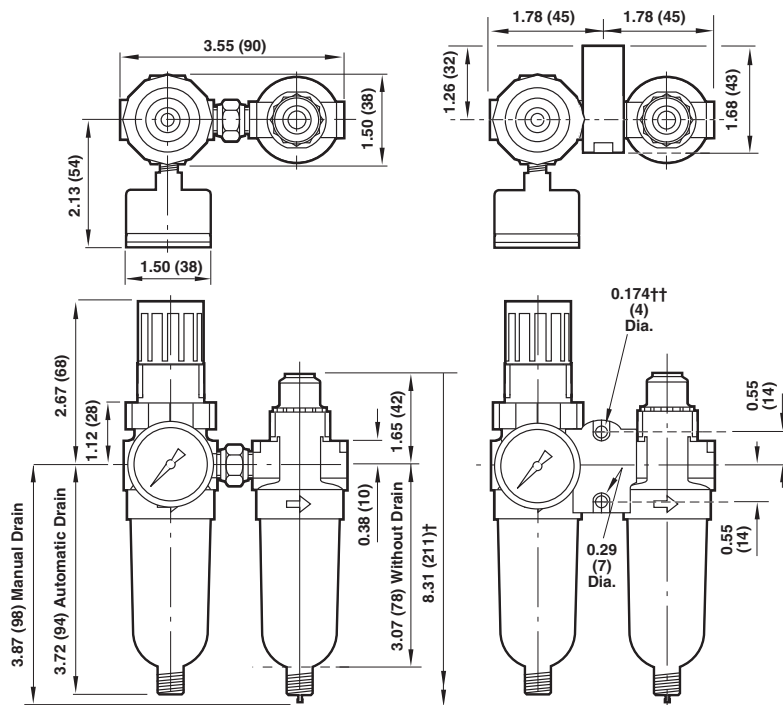

† Minimum distance required to remove bowl  
 †† Mounting holes

All Dimensions in Inches (mm)

## Service Kits

Item	Type	Part number
Service kits, filter/regulator	relieving, 5 μm element non relieving, 5 μm element	3820-02 3820-01
Service kit, lubricator		3795-03
Replacement drains	Manual Automatic	773-03 3654-02
Replacement wall bracket for PTH unit	Integral 2 piece	6700-30

Filter/regulator service kit contains slip ring, diaphragm, valve seat with o-ring, valve, valve spring, element, element gasket, and bowl o-ring.  
 Lubricator service kit contains sight-feed dome seal, cartridge o-ring, and bowl o-ring.

# F07

## Miniature Series 07 General Purpose Filter

1/8" and 1/4" Port Sizes

### Compact design

Protects air operated devices by removing liquid and solid contaminants

### Technical data

Fluid:

Compressed air

Maximum pressure:

Transparent bowl: 150 psig (10 bar)

Metal bowl: 250 psig (17 bar)

Operating temperature:\*

Transparent bowl:

-30° to 125°F (-34° to 50°C)

Metal bowl:

-30° to 175°F (-34° to 80°C)

\* Air supply must be dry enough to avoid ice formation at temperatures below 35°F (2°C)

Particle removal:

5 µm or 40 µm filter element

Air quality:

Within ISO 8573-1, Class 3 and Class 5 (particulates)

Drain connection:

1/8" male pipe thread

Materials

Body: zinc

Transparent bowl: Polycarbonate

Metal bowl: Zinc (without sight glass)

Element: sintered polypropylene

Elastomers: neoprene & nitrile



### Ordering Information

Models listed include PTF threads, automatic drain, transparent bowl and 5 µm element.

Port Size	Model Numbers	Flow scfm (dm <sup>3</sup> /s) *	Weight lbs (kg)	Replacement elements	Service kit**
1/8"	F07 100 A1TA	19 (9)	0.28 (0.13)	3652-17 (5µm)	3652-17
1/4"	F07 200 A1TA	24 (11.5)	0.28 (0.13)	3652-18 (40µm)	3652-18

\* Approximate flow at 90 psig (6.3 bar) inlet pressure and 5 psig (0.35 bar) pressure drop.

\*\* Service kit includes element, element gasket, and bowl o-ring.

### Alternative Models

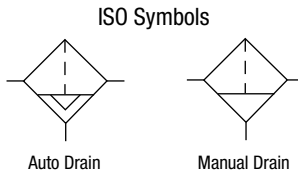
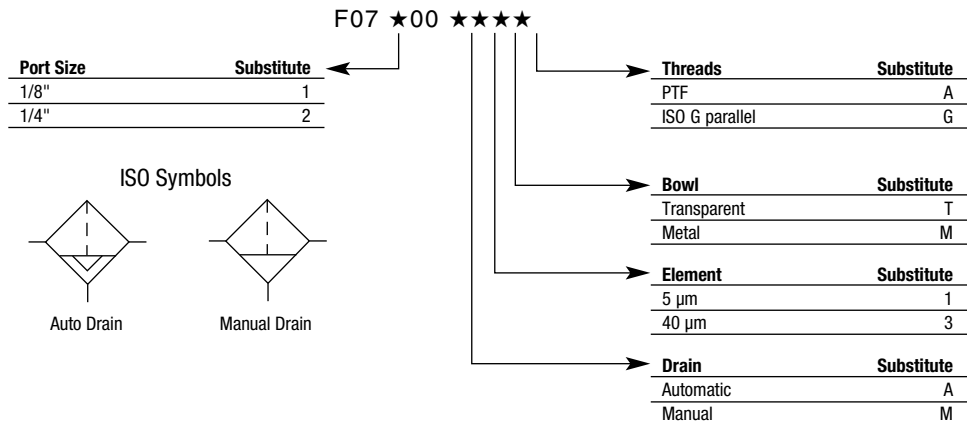

### Typical Performance Characteristics

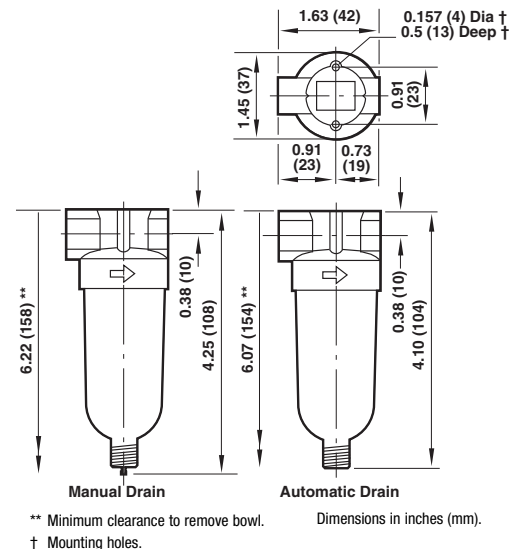
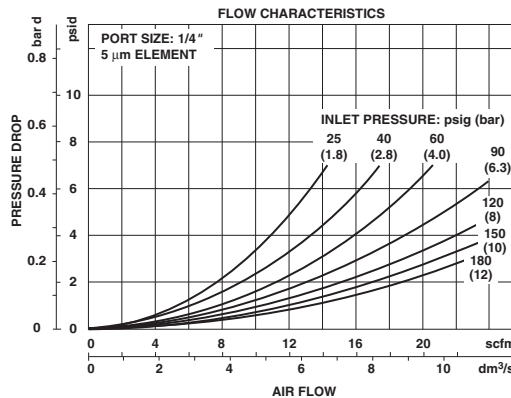

# F39

## Oil removal (Coalescing) Filter

1/8" and 1/4" Port Sizes

ISO Symbols

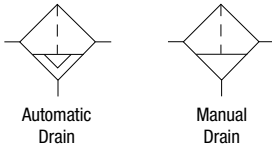

### Compact design

High efficiency oil and particle removal

### Technical data

Fluid:

Compressed air

Maximum pressure:

Transparent bowl: 150 psig (10 bar)

Metal bowl: 250 psig (17 bar)

Operating temperature:\*

Transparent bowl:

-30° to 125°F (-34° to 50°C)

Metal bowl:

-30° to 150°F (-34° to 65°C)

\* Air supply must be dry enough to avoid ice formation at temperatures below 2°C (35°F)

Aerosol oil removal:

Down to 0.01 µm

Air quality:

Within ISO 8573-1, Class 1 (particulates) and Class 2 (oil content)

Maximum remaining oil content of air leaving the filter: 0.01ppm at 70°F (21°C) with an inlet oil concentration of 17 ppm.

Maximum flow with 90 psig (6.3 bar) inlet pressure†:

1/8 ports, 6.0 scfm (2.8 dm3/s)

1/4 ports, 6.4 scfm (3 dm3/s)

† Maximum flow to maintain stated oil removal performance.

Nominal bowl size:

1 fluid ounce (31 ml)

Drain connection:

1/8" male pipe thread

Automatic drain operation:

Spitter type drain operates momentarily when a rapid change in air flow occurs or when the supply pressure is reduced.

Materials

Body: Zinc

Bowl: Transparent: Polycarbonate

Metal: Zinc

Element: Synthetic fiber and polyurethane foam

Elastomers: Neoprene & nitrile

### Ordering Information

Models listed include PTF threads, automatic drain and transparent bowl.

Port Size	Model Numbers	Saturated Flow* scfm (dm3/s)	Dry Flow scfm (dm3/s)	Weight lbs (kg)	Element Kit**
1/8"	F39 100 A0TA	6.0 (2.8)	11.2 (5.3)	0.28 (0.13)	4141-10
1/4"	F39 200 A0TA	6.4 (3.0)	12.2 (5.8)	0.28 (0.13)	4141-10

\* Maximum flow at 90 psig (6.3 bar) inlet pressure to maintain stated oil removal performance.

\*\* Includes element and O-rings

### Alternative Models

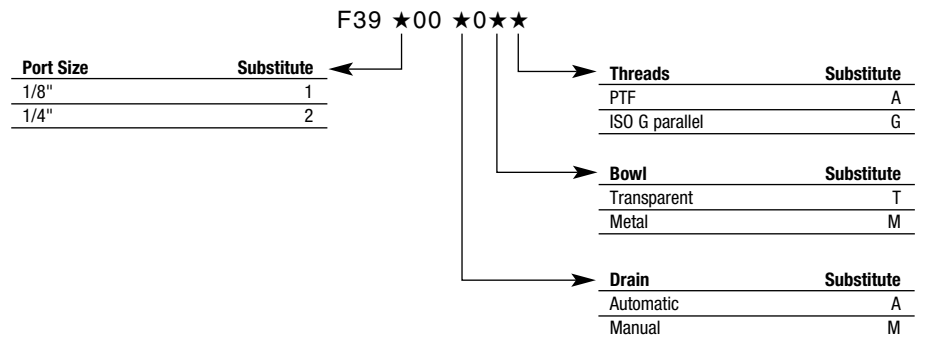

### Typical Performance Characteristics

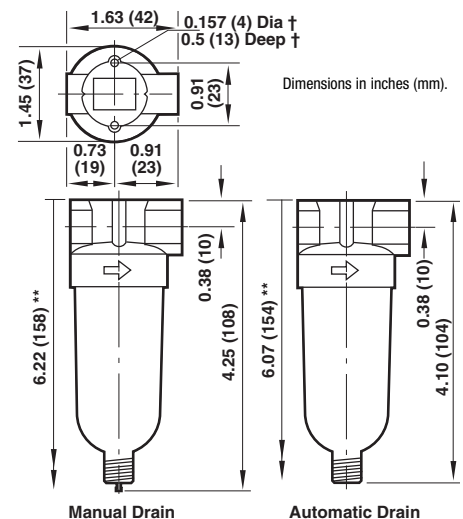
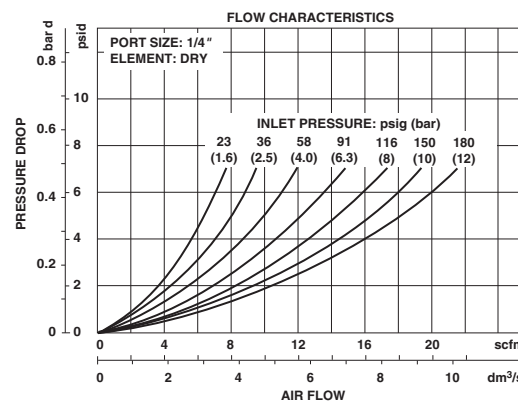

\*\* Minimum clearance to remove bowl.  
† Mounting holes.

# Miniature Filter/Regulators

## B07, and B39

- Full flow gauge ports
- High efficiency oil and particle removal
- Excellent flow and regulation characteristics

### Technical data

#### B07

Fluid:

Compressed air

Maximum pressure

Transparent bowl: 150 psig (10 bar)

Metal bowl: 250 psig (17 bar)

Operating temperature\*

Transparent bowl:

30° to 125°F (-34° to 50°C)

Metal bowl:

-30° to 150°F (-34° to 65°C)

\* Air supply must be dry enough to avoid ice formation at temperatures below 35°F (2°C)

#### B39

Maximum pressure

Transparent bowl: 150 psig (10 bar)

Metal bowl: 250 psig (17 bar)

Operating temperature\*

Transparent bowl:

-30° to 125°F (-34° to 50°C)

Metal bowl:

-30° to 150°F (-34° to 65°C)

\* Air supply must be dry enough to avoid ice formation at temperatures below 35°F (2°C)

### Materials

#### B07

Body: zinc

Bonnet: acetal

Valve seat: acetal

Transparent bowl: polycarbonate

Metal: zinc

Element: sintered polypropylene

Elastomers: nitrile

#### B39

Body: zinc

Bonnet: acetal

Valve: brass/nitrile

Valve seat: acetal

Transparent bowl: Polycarbonate

Metal: zinc

Element: synthetic fiber and

polyurethane foam

Elastomers: nitrile



B07

B39

### Ordering Information

Models listed include PTF threads, transparent bowl, relieving diaphragm, gauge, automatic drain, 5 to 100 psig (0.3 to 7 bar) outlet pressure adjustment range\* .

Port Size	Model Number	Flow scfm (dm <sup>3</sup> /s)	Weight lbs (kg)
1/8"	B07 102 A1KA	13 (6.2 dm <sup>3</sup> /s)	0.57 (0.26)
1/4"	B07 202 A1KA	14 (6.5 dm <sup>3</sup> /s)	0.57 (0.26)
1/8"	B39 102 A0KA	4.0 (1.9)	0.57 (0.26)
1/4"	B39 202 A0KA	4.0 (1.9)	0.57 (0.26)

\*Outlet pressure can be adjusted to pressures in excess of, and less than, those specified. Do not use these units to control pressures outside of the specified ranges.

### ISO Symbols

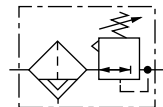

Automatic Drain Relieving

# Miniature Filter/Regulators

**B07, and B39**

Dimensions in inches (mm).

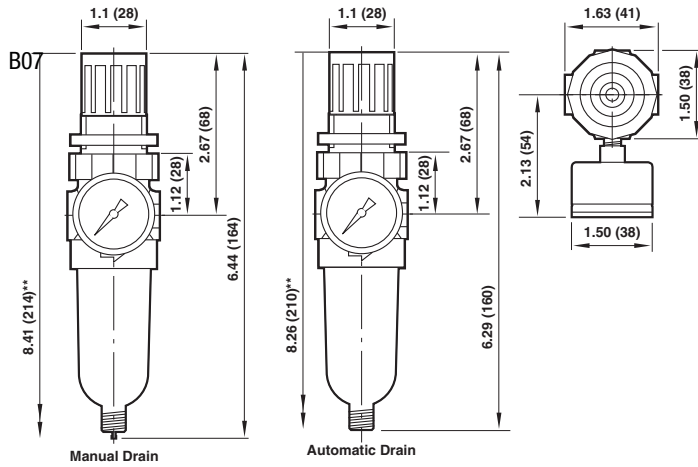

\*\* Minimum clearance to remove bowl  
 Panel mounting hole diameter 1.19" (30 mm)  
 Panel thickness: 0.25" (6 mm)

## Typical Performance Characteristics

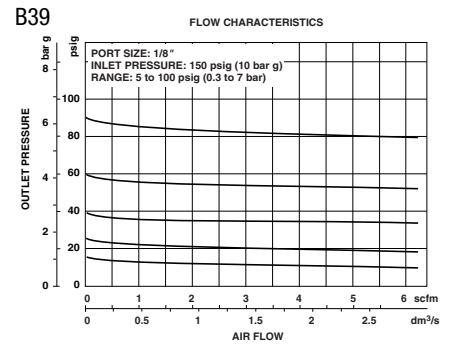
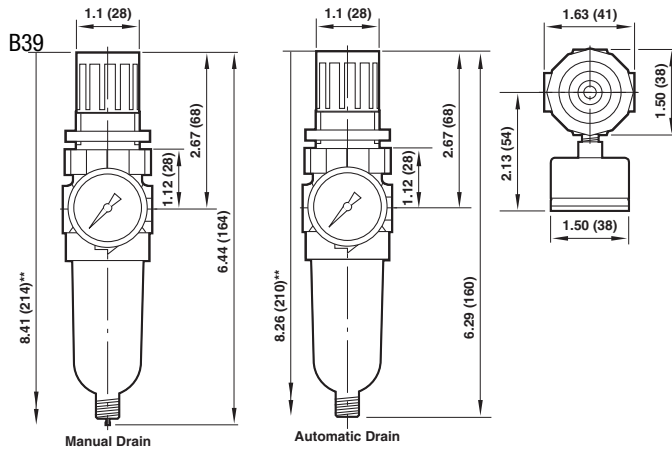
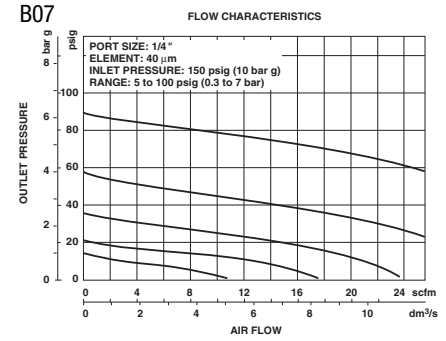

# Miniature General Purpose Regulators

## R07, R46

### R07 General purpose

Snap action knob locks pressure setting when pushed in

Standard relieving models allow reduction of outlet pressure even when the system is dead-ended

### R46 Non-repairable

Wrench flats for easy installation

Relieving piston design allows reduction of downstream pressure when the system is dead-ended

Choice of left to right or right to left flow



R07



R46

### Technical data

#### R07

Fluid:

Compressed air

Maximum pressure:

300 psig (20 bar)

Operating temperature:

-34° to 150°F (-35° to 65°C) \*

\* Air supply must be dry enough to avoid ice formation at temperatures below 2°C (35°F).

#### R46

Fluid:

Compressed air

Maximum pressure:

250 psig (17 bar)

Operating temperature\*:

-30° to 150°F (-34° to 65°C)

\* Air supply must be dry enough to avoid ice formation at temperatures below 35°F (2°C).

### Materials

#### R07

Body: zinc

Bonnet: acetal

Knob: Acetal

Valve seat: acetal

Elastomers: nitrile

#### R46

Body: zinc

Knob: nylon

Valve: nitrile compound

Valve seat: acetal

Elastomers: nitrile

### Ordering Information

Port Size	Model	Flow† scfm (dm <sup>3</sup> /s)	Weight lb (kg)
1/8"	R07 100 RGKA	14 (6.5)	0.31 (0.19)
1/4"	R07 200 RGKA	15 (7)	0.31 (0.19)
1/4"	R46 200 RGLA	13 (6)	0.2 (0.09)

\* Air supply must be dry enough to avoid ice formation at temperatures below 35°F (2°C)

† Typical flow with 150 psig (10 bar) inlet pressure, 90 psig (6.3 bar) set pressure and 15 psig (1 bar) droop from set.

### Alternative Models

R07 ★00 ★★ ★★ ★★★★★

Port Size	Substitute	Threads	Substitute
1/8"	1	PTF	A
1/4"	2	ISO G parallel	G

Diaphragm	Substitute	Outlet Pressure Adjustment Ranges*	Substitute
Relieving	R	1 to 10 psig (0.1 to 0.7 bar)	A
Non relieving	N	5 to 50 psig (0.3 to 3.5 bar)	E
		5 to 100 psig (0.3 to 7 bar)	K
		5 to 125 psig (0.3 to 8.6 bar)	L

Gauges	Substitute
With	G
Without	N

R46-★★★★-R★★★★

Port Size	Substitute	Threads	Substitute
1/4"	2	PTF	A
		ISO G parallel	G

Flow Direction With Knob Up and Gauge Visible	Substitute	Outlet Pressure Adjustment Ranges*	Substitute
Left to Right	00	5 to 50 psig (0.3 to 3.5 bar)	E
Right to Left	02	5 to 125 psig (0.3 to 8.5 bar)	L
		5 to 150 psig (0.3 to 10 bar)	M

Gauges	Substitute
With	G
Without	N

\* Outlet pressure can be adjusted to pressures in excess of, and less than, those specified. Do not use these units to control pressures outside of the specified ranges.

### ISO Symbols

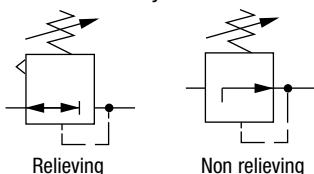

# Miniature General Purpose Regulators

R07, R46

Dimensions in inches (mm).

Panel mounting hole diameter 1.19" (30 mm)  
Maximum panel thickness 0.25" (6 mm)

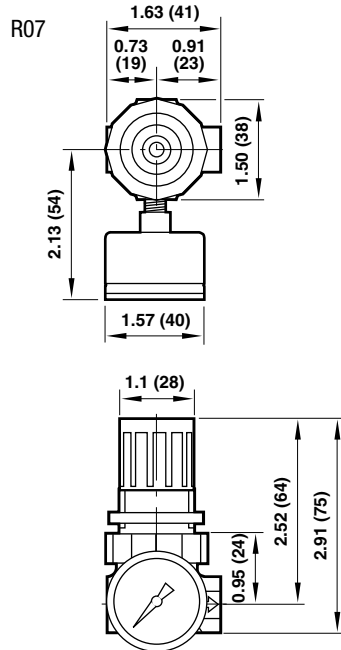

All Dimensions in Inches (mm)

## Typical Performance Characteristics

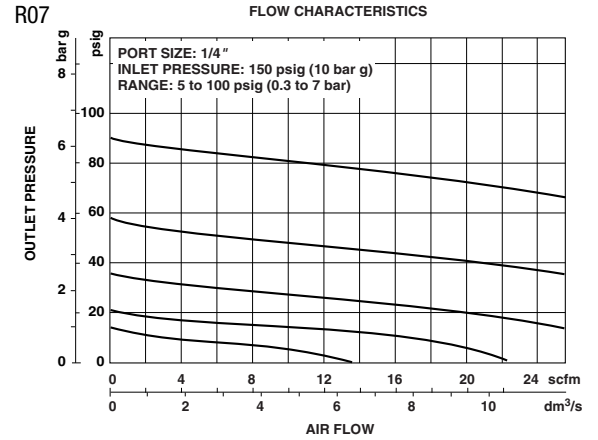

### R07 Service Kits

Item	Type	Part number
Service kit	Relieving	3407-02
	Non relieving	3407-01

Service kit includes slip ring, diaphragm, standard valve seat with o-ring, valve, valve spring.

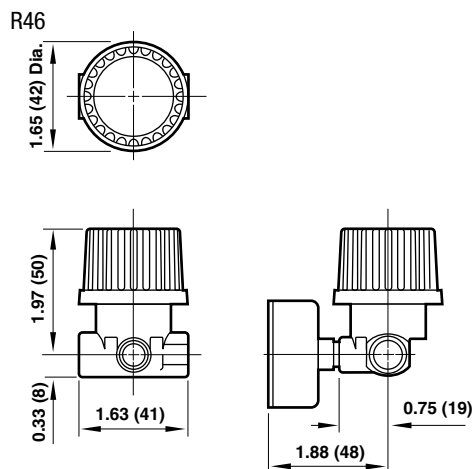

## Typical Performance Characteristics

