

# Stainless Steel Products

## R05, and B05

Designed for use in corrosive environments

Metallic parts meet NACE Standard MR-01-75\*

Meets certain requirements of Military Specifications\*\*

\* National Association of Corrosion Engineers (NACE) MR-01-75 defines requirements for sulphide stress cracking resistant materials used in well-head and other corrosive environments.

\*\* Meets certain requirements of MIL-S-901C (Navy) 15 Jan 1963: Military Specifications Shock Test H.I. (High Impact); Shipboard Machinery, Equipment and Systems and MIL-STD-167-1 (Ships) Military Standard Mechanical Vibrations of Shipboard Equipment.

### Technical data

R05

Fluid:

Compressed air

Maximum pressure:

250 psig (17 bar)

Operating temperature:

-30° to 150°F (-34° to 66°C) \*

\* Air supply must be dry enough to avoid ice formation at temperatures below 35°F (2°C).

B05

Fluid:

Compressed air

Maximum pressure:

250 psig (17 bar)

Operating temperature:

-30° to 150°F (-34° to 66°C) \*

\* Air supply must be dry enough to avoid ice formation at temperatures below 35°F (2°C)

Particle removal:

5 µm or 40 µm filter element

Materials

R05

Body: 316 stainless steel

Bonnet: Acetal with stainless steel adjusting screw

Valve: Stainless steel with fluorocarbon elastomer

Valve seat: Acetal

Springs: Stainless steel

Elastomers: Fluorocarbon

B05

Body and bowl: 316 stainless steel

Bonnet: Acetal with stainless steel adjusting screw

Valve: Stainless steel with fluorocarbon elastomer

Valve seat: Acetal

Springs: Stainless steel

Drain: Acetal

Element: Sintered polypropylene

Elastomers: Fluorocarbon



R05

B05

### R05 Ordering Information

Model listed is relieving type with 5 to 125 psig (0.3 to 8.5 bar) outlet pressure adjustment range\*\* and PTF threads. A gauge is not included.

Port Size	Model	Bonnet type	Flow† scfm (dm <sup>3</sup> /s)	Weight lb (kg)
1/4" PTF	R05-200-RNLA	Acetal	7 (3.3)	0.41 (0.19)
1/4" PTF	R05-232-RNLA	Stainless steel w/ T-handle	7 (3.3)	0.67 (0.30)

† Typical flow with 100 psig (7 bar) inlet pressure, 90 psig (6.3 bar) set pressure and 15 psig (1 bar) droop from set.

### B05 Ordering Information

Model listed includes a relieving diaphragm, manual drain, 40 µm element, 5 to 125 psig (0.3 to 8.5 bar) outlet pressure adjustment range\*\* and PTF threads. A gauge is not included.

Port Size	Model	Bonnet type	Flow† scfm (dm <sup>3</sup> /s)	Weight lb (kg)
1/4" PTF	B05-233-M2LA	Acetal	7 (3.3)	0.99 (0.45)
1/4" PTF	B05-238-M2LA	Stainless steel w/ T-handle	7 (3.3)	1.34 (0.61)

\*\* Outlet pressure can be adjusted to pressures in excess of, and less than, those specified. Do not use these units to control pressures outside of the specified ranges.

† Typical flow with 100 psig (7 bar) inlet pressure, 90 psig (6.3 bar) set pressure and 15 psig (1 bar) droop from set.

### Accessories

Panel nut

0 ... 140 psig



2962-89



18-013-844

\* Bracket kit does not include wall mounting screws.

### ISO Symbols

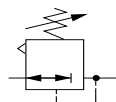

R05 Relieving

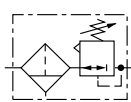

B05 Manual Drain, Relieving

# Stainless Steel Products

R05, and B05

Dimensions in inches (mm)

Panel mounting hole diameter: 1.19" (30 mm)  
 Panel thickness: .25" (6 mm)

R05

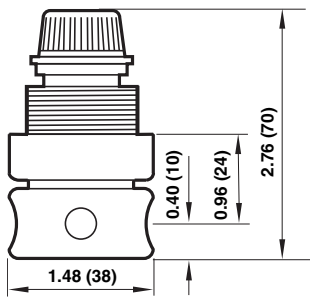
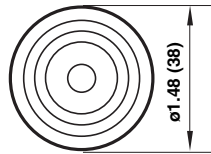

Panel mounting hole diameter: 1.19" (30 mm)  
 Panel thickness: .25" (6 mm)

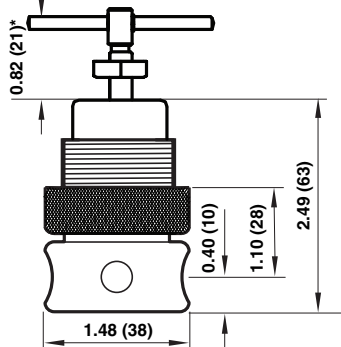
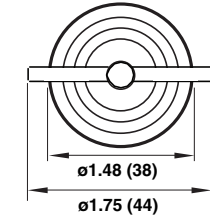

\*Maximum dimension (minimum clearance required for open position)

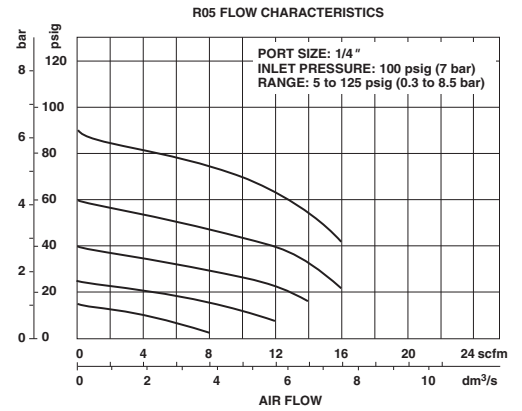

B05

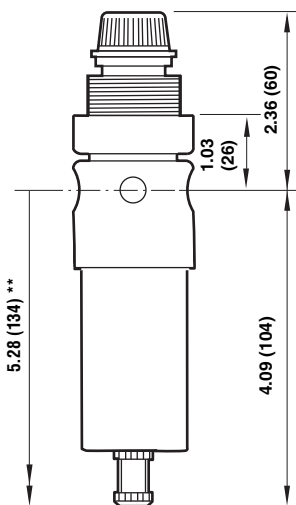
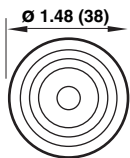

Manual Drain

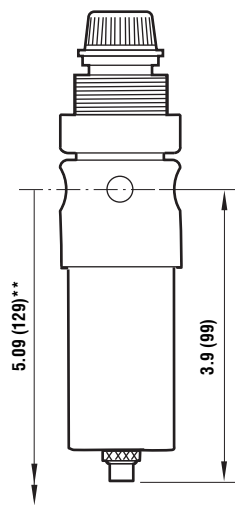

Automatic Drain

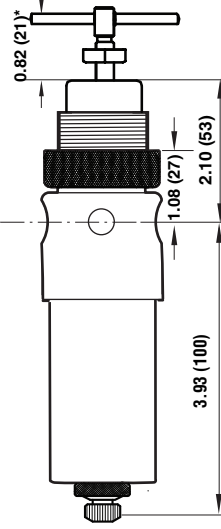
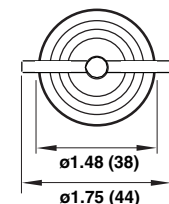

Automatic Drain

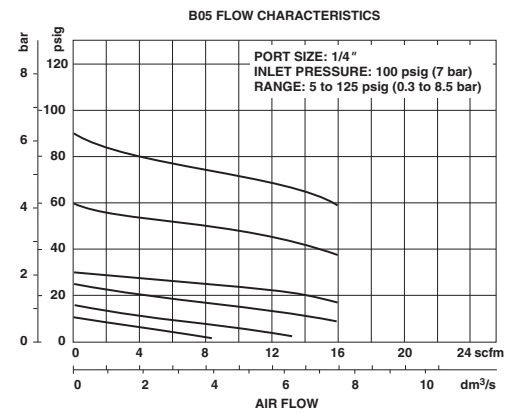

# Stainless Steel Products

## R38, and B38

Designed for use in corrosive environments

Metallic parts meet NACE Standard MR-01-75\*

Meets certain requirements of Military Specifications\*\*

\* National Association of Corrosion Engineers (NACE) MR-01-75 defines requirements for sulphide stress cracking resistant materials used in well-head and other corrosive environments.

\*\* Meets certain requirements of MIL-S-901C (Navy) 15 Jan 1963: Military Specifications Shock Test H.I. (High Impact); Shipboard Machinery, Equipment and Systems and MIL-STD-167-1 (Ships) Military Standard Mechanical Vibrations of Shipboard Equipment.

### Technical data

#### R38

Fluid:

Compressed air

Maximum pressure:

450 psig (31 bar)

Operating temperature:

-40° to 175°F (-40° to 80°C) \*

\* Air supply must be dry enough to avoid ice formation at temperatures below 35°F (2°C).

#### B38

Fluid:

Compressed air

Maximum pressure:

Manual drain: 450 psig (31 bar)

Automatic drain: 250 psig (17 bar)

Operating temperature:

-40° to 175°F (-40° to 80°C) \*

\* Air supply must be dry enough to avoid ice formation at temperatures below 35°F (2°C).

Particle removal:

5 µm or filter element

Materials

#### R38

Body: Stainless steel

Bonnet: Stainless steel

Adjusting screw: Stainless steel

Elastomeric materials: Nitrile

B38 (standard option)

Body: Stainless steel

Bonnet: Stainless steel

Bowl: Stainless steel

Adjusting screw: Stainless steel

Elements

5 µm: High density polyethylene

1/4" only 5 µm: Ceramic pyrolyth

Elastomeric materials: Nitrile



R38

B38

### R38 Ordering Information

Models listed are relieving type with 0.6 to 30 psig (0.04 to 2 bar) outlet pressure adjustment range \*\*, and PTF threads. A gauge is not included.

Port Size	Model Number	Flow† scfm (dm <sup>3</sup> /s)	Weight lbs (kg)
1/4" PTF	R38-240-RNCA	17 (8)	1.56 (0.71)

\*\* Outlet pressure can be adjusted to pressures in excess of, and less than, those specified. Do not use these units to control pressures outside of the specified ranges.

† Typical flow with 100 psig (7 bar) inlet pressure, 15 psig (1 bar) set pressure and 1 psig (0.05 bar) droop from set.

### B38 Ordering Information

Models listed are relieving type with manual drain, 5µm element, and PTF threads. A gauge is not included.

Port Size	Model Number	Outlet pressure range psig (bar)	Flow** scfm (dm <sup>3</sup> /s)	Weight kg (lbs)
1/4" PTF	B38-240-B1KA	4 to 100 (0.3 to 7)	15 (7)	3.11 (1.4)
1/2" PTF	B38-440-M1LA	4 to 125 (0.3 to 9)	106 (50)	4.75 (2.2)

\*\* Typical flow with 175 psig (12 bar) inlet pressure, 115 psig (8 bar) set pressure and 15 psig (1 bar) droop from set.

### Accessories

Neck mounting bracket



18-001-959

Gauge  
0 ... 140 psig



18-013-909

\* Bracket kit does not include wall mounting screws.

### ISO Symbols

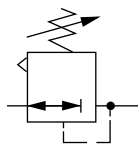

R38

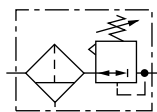

B38 Manual Drain, Relieving

# Stainless Steel Products

**R38, and B38**  
Dimensions in inches (mm)

Panel mounting hole diameter: 1.65" (42 mm)  
Maximum panel thickness: 0.24" (6 mm)

**R38**

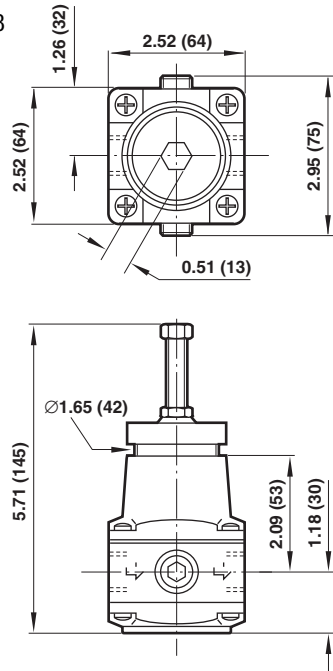

**R38**

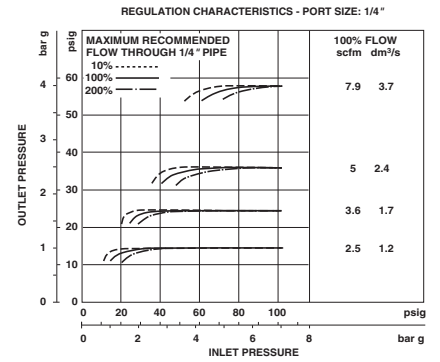
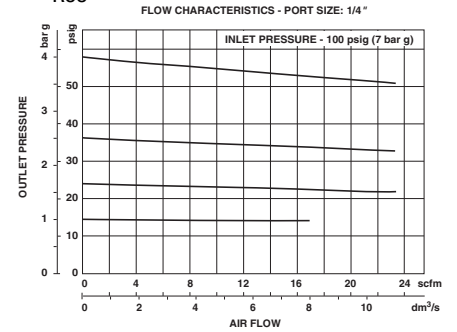

**B38**

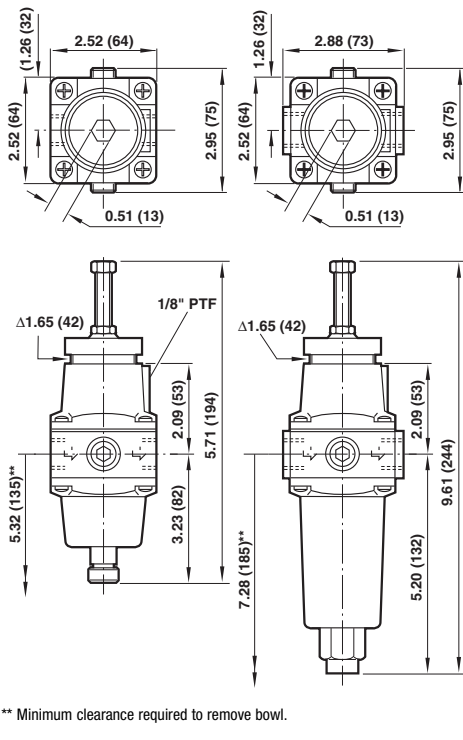

Panel mounting hole diameter: 1.65" (42 mm)  
Maximum panel thickness: 0.24" (6 mm)

**B38**

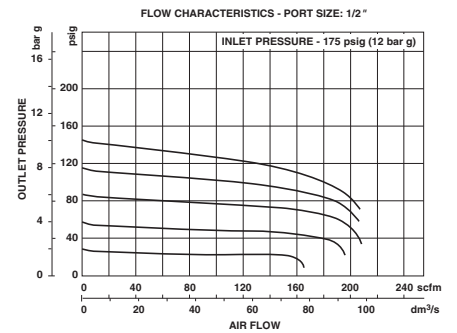
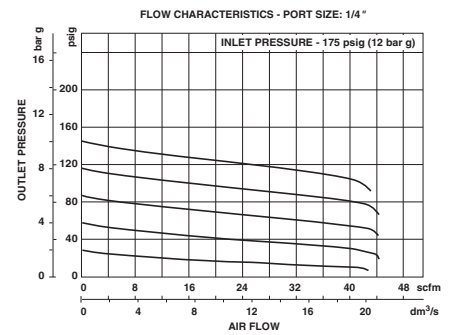

\*\* Minimum clearance required to remove bowl.

# Stainless Steel Products

## F22, R22, L22

### ISO Symbols

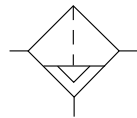

F22 Automatic Drain

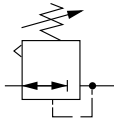

R22 Relieving

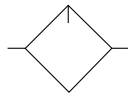

L22 No Drain

Designed for use in corrosive environments

Metallic parts meet NACE Standard MR-01-75\*

Meets certain requirements of Military Specifications\*\*

\* National Association of Corrosion Engineers (NACE) MR-01-75 defines requirements for sulphide stress cracking resistant materials used in well-head and other corrosive environments.

\*\* Meets certain requirements of MIL-S-901C (Navy) 15 Jan 1963; Military Specifications Shock Test H.I. (High Impact); Shipboard Machinery, Equipment and Systems and MIL-STD-167-1 (Ships) Military Standard Mechanical Vibrations of Shipboard Equipment.

### Technical data

#### F22

Fluid:

Compressed air

Maximum pressure:

250 psig (17 bar)

Operating temperature:

0° to 175°F (-20° to 80°C)\*

\* Air supply must be dry enough to avoid ice formation at temperatures below 35°F (2°C).

Particle removal:

5 µm optional

Air quality:

Within ISO 8573-1, Class 3 and Class 5 (particulates)

#### R22

Fluid:

Compressed air

Maximum pressure:

290 psig (20 bar)

Operating temperature:

-4° to 175°F (-20° to 80°C)\*

\* Air supply must be dry enough to avoid ice formation at temperatures below 35°F (2°C).

#### L22

Fluid:

Compressed air

Maximum pressure:

250 psig (17 bar)

Operating temperature:

-4° to 175°F (-20° to 80°C)\*

\* Air supply must be dry enough to avoid ice formation at temperatures below 35°F (2°C).



F22

R22

L22

### Filters

Model listed has PTF threads, automatic drain, and 25 µm element.

Port Size	Model Number	Flow† scfm (dm <sup>3</sup> /s)	Weight lbs (kg)
1/2 PTF	F22-405-A2DA	98 (46)	4.18 (1.88)

† Typical flow with element at 90 psig (6.3 bar) inlet pressure, and 5 psig (0.35 bar) pressure drop.

### Regulators

Models listed have T-handle adjustment, relieving diaphragm, 5 to 150 psig (0.4 to 10 bar) outlet pressure adjustment range and PTF threads. A gauge is not included.

Port Size	Model Number	Flow** scfm (dm <sup>3</sup> /s)	Weight lbs (kg)
1/2 PTF	R22-401-RNMA (T-handle adjustment)	106 (50)	3.35 (1.52)
1/2 PTF	R22-405-RNMA (handwheel adjustment)	106 (50)	3.35 (1.52)

\*\* Typical flow with 150 psig (10 bar) inlet pressure, 90 psig (6.3) set pressure, and a 15 psig (1 bar) droop from set.

### Lubricators

Model listed is oil-fog unit with closed bowl (no drain) and PTF threads.

Type	Model Number	Flow† scfm (dm <sup>3</sup> /s)	Weight lbs (kg)
Oil-Fog	L22-405-OP8A	102 scfm (48 dm <sup>3</sup> /s)	4.29 (1.93)

† Typical flow with 90 psig (6.3 bar) inlet pressure and 7 psig (0.5 bar) pressure drop.

### Materials

#### F22

Body: Stainless steel

Bowl: Stainless steel

Element: Sintered stainless steel

Elastomers: Nitrile

#### R22

Body: Stainless steel

Bonnet: Stainless steel

Adjusting screw: Stainless steel

Handwheel: Stainless steel, acetal

Elastomers: Nitrile

#### L22

Body: Stainless steel

Bowl: Stainless steel

Elastomers: Nitrile

### Accessories

Neck mounting bracket



18-001-959

Wall mounting bracket



18-001-962

Gauge  
0 ... 140 psig



18-013-909

\* Bracket kit does not include wall mounting screws.

# Stainless Steel Products

**F22, R22, L22**  
Dimensions in inches (mm)

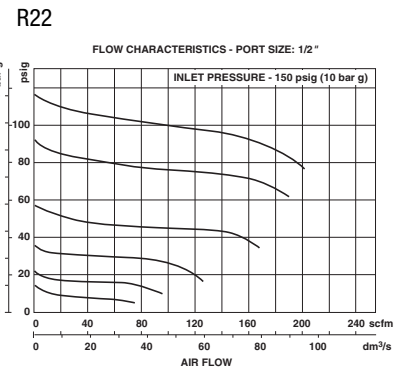
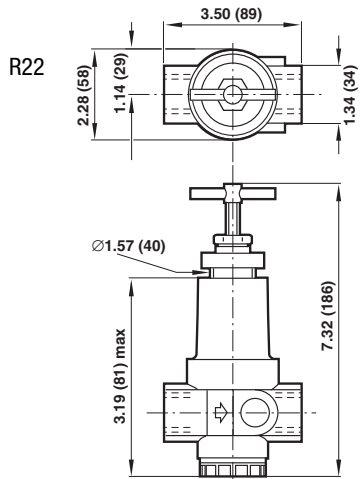
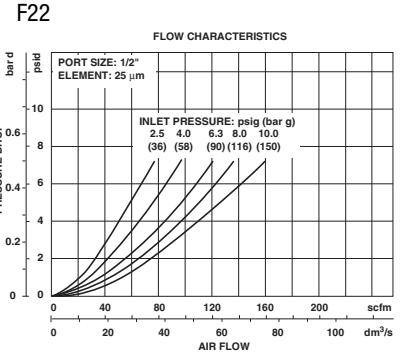
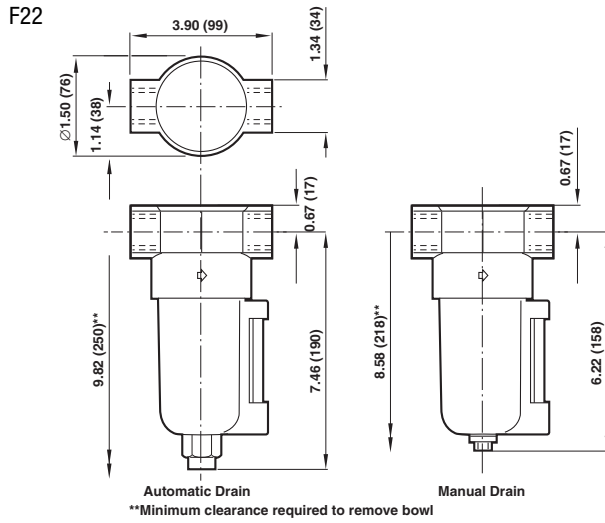

Panel mounting hole diameter: 1.65" (42 mm)  
Maximum Panel thickness: 0.37" (9.5 mm)

