

The Manostat precision pressure regulator series are designed for critical pressure control applications and have demonstrated outstanding reliability and durability in many thousands of applications worldwide. It is suitable for dead-end (closed load) conditions and can be supplied on its own or with a visual display dial.

Other versions include; plunger, lever operated and volume boosting air relay (see separate datasheet).

- Reliable, durable
- Precise regulation
- Excellent setting sensitivity
- High relief
- Versatile design for varied applications

**TYPICAL APPLICATIONS**

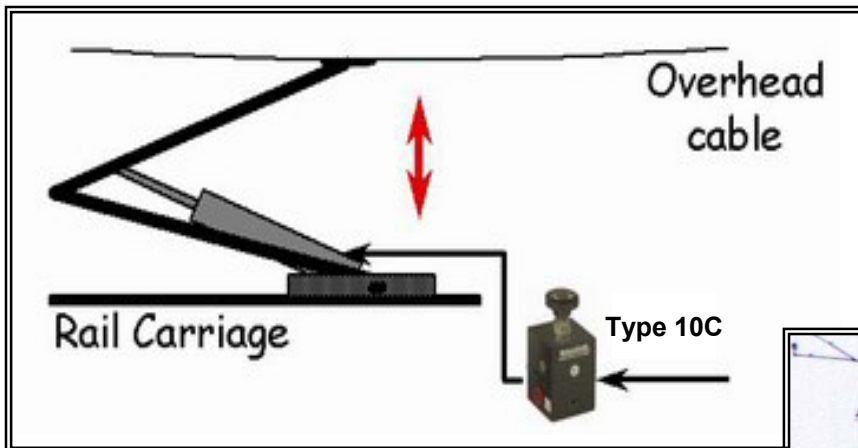

**Solution:**

The Manostat controls the vertical pressure between the pantograph and the cable. This requires rapid operation (high flow) as well as stability across a wide temperature range



**Industry:**

Railway Pantograph system and Trams



## TECHNICAL DATA

### Pneumatic

- Output Signal See ordering information - Pressure range can be limited by resetting the locknuts provided
- Air Supply Oil free, dry air or other dry gases, filtered to better than 25 microns; at least 0.2bar (3psig) above output pressure to a maximum of 10bar (150psig, 1000kPa)
- Flow Capacity Up to 300NI/min (10scfm).
- Air Consumption 0.2 l/min (0.006scfm) at 1bar (15psig);  
0.3 l/min (0.01scfm) at 1.7bar (25psig);  
0.6 l/min (0.02scfm) at 4bar (60psig);  
1.2 l/min (0.04scfm) at 8bar (120psig) (typical values at maximum supply pressure)
- Response Time less than 0.2 seconds for 50% load change
- Regulation % output change for 1bar/15psi supply Accuracy pressure change at mid-range output: 0.1% (0.14bar/2 to 25psi), 0.05% (0.14-4bar/2 to 60psi), 0.02% (0.14-8bar/2 to 120psi)
- Sensitivity Better than 0.3mbar (0.005psi)
- Hysteresis and Repeatability Typically less than 0.05% setting at mid-range
- Temperature Effect Typically better than  $\pm 1\%$  change of full span between  $-20^{\circ}\text{C}$  and  $+70^{\circ}\text{C}$
- Connections  $1/4"$  NPT female standard (plus two integral  $1/4"$  NPT gauge ports); others on request

### Physical

- Operating Temperature  $-20^{\circ}\text{C}$  to  $+70^{\circ}\text{C}$
- I.P. Rating IP65
- Vibration The unit is unaffected by moderate vibration
- Material of Construction Zinc diecasting passivated and epoxy painted, Beryllium copper capsule; Nitrile diaphragms

### Model Types

- Handwheel: Basic manostat unit with pressure adjusting handwheel; mounting in any attitude, integral mounting nut supplied
- Dial manostat: Manual pressure loading unit combining a manostat regulator with a 4" diameter gauge
- DIN manostat: As above but with a DIN standard pressure gauge
- DMW: Weatherproof version of dial manostat with 100mm diameter gauge; pneumatic connections taken to lower face of casing; surface or post mounting (yoke supplied suitable for a 50mm/2" diameter post); casing is polycarbonate, grey finish to IP55

#### Volume Boosting Air Relay (manual bias):

Remote control of regulated pressures is possible with minimal air usage; positive or negative bias between pilot signal and regulated pressure can be set up of up to 2bar/30psig

**Note:** a small pressure ( $<2\text{psig}$ , 0.14bar) will show at the lower end of dial manostats gauge scale (due to regulator servo operation)

# Handwheel Manostat Diagrams

## Handwheel Manostat

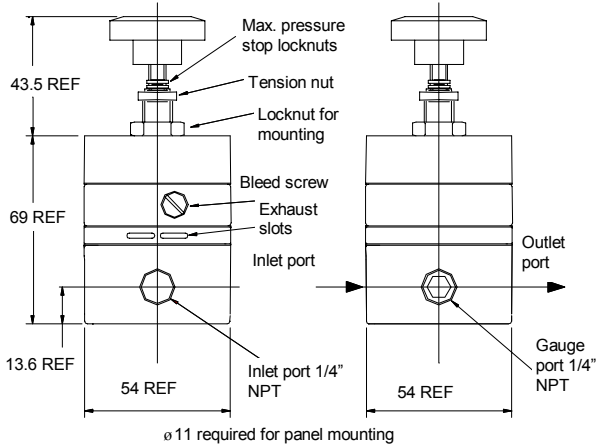

# Characteristic Graphs

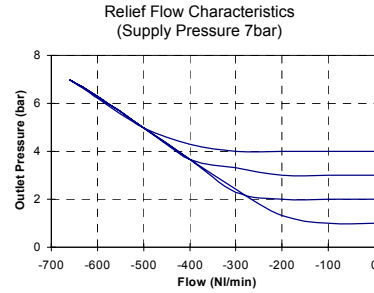
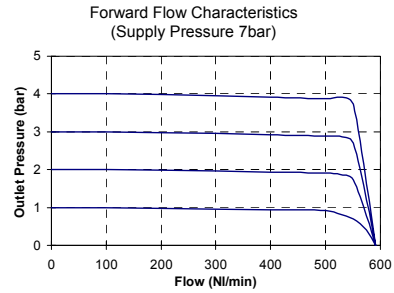

## Ordering Information

Handwheel manostats		
Output pressure		Order code
0.14-1.7bar, 2-25psig	Standard	100200R
0.14-4bar, 2-60psig	Standard	100300R
0.14-8bar, 2-120psig	Standard	100400R

# Characteristic Graphs

## Manual Bias Relay

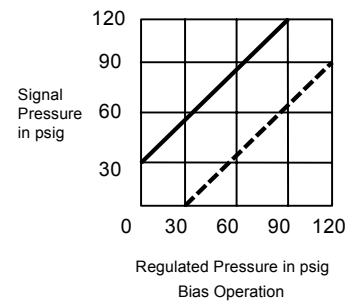
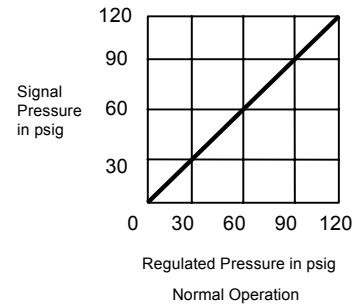
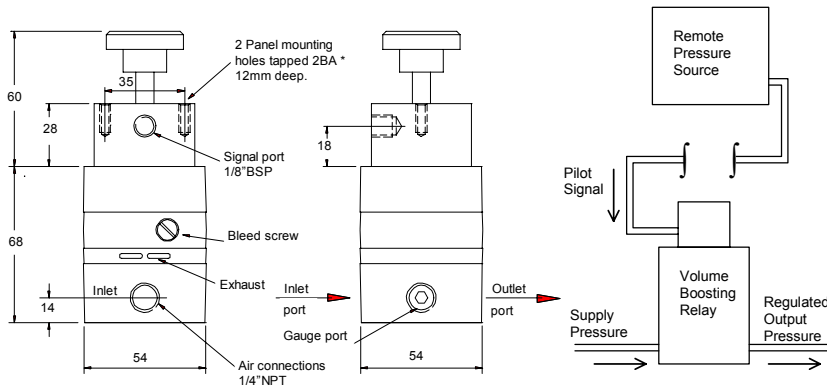

## Ordering Information

Manual bias relay		
Output pressure		Order code
0.2-1bar, 3-15psig	Standard	220100R
0.14-8bar, 2-120psig	Standard	220400R

# Dial / Din Manostat Diagrams

## Dial Manostat

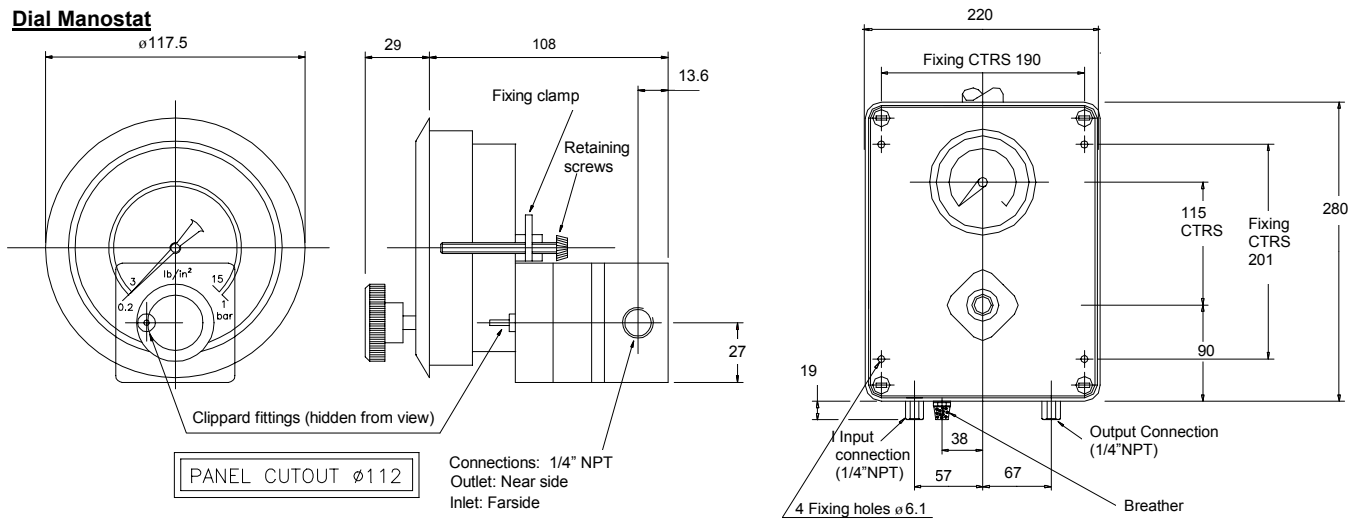

## DIN Manostat

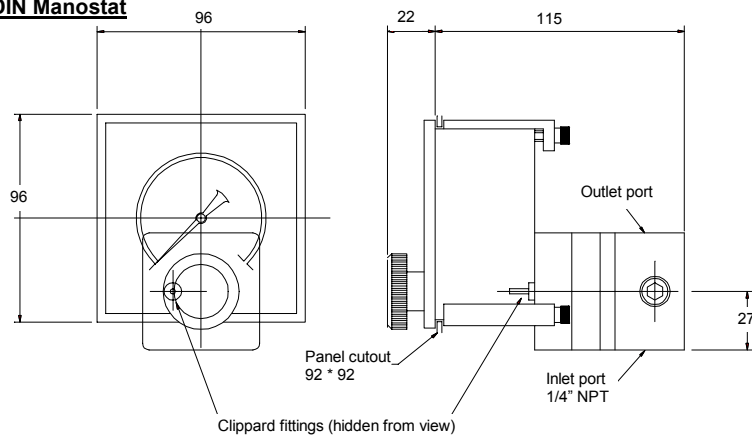

## Weatherproof Dial Manostat

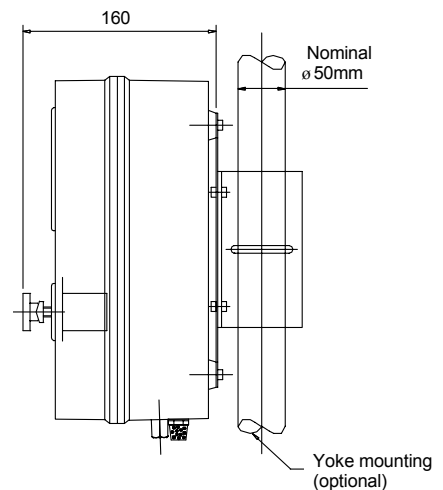

## Ordering Information

DIN / Dial manostats				
Pressure range	Scale	Dial	DIN	Weatherproof (DMW)
0.2-1bar, 3-15psig	Dual	300100R		320100R
0-2bar, 0-30psig	Dual	301200R		
0-4bar, 0-60psig	Dual	301300R	311300R	
0-8bar, 0-120psig	Dual	301400R	311400R	321400R
3-15psig	0-100%	309100R	319100R	329100R
20-100kPa	0-100%		319200R	

Options to special order: Captured bleed version of handwheel manostat suitable for natural gas applications available. Factory fitting of a reduction gearbox to handwheel manostat (change "00R" to "96R"). Yoke mounting for Weatherproof Manostat (change "00R" to "10R"). Special scale calibrations for Dial Manostats. Alternative pneumatic connections. Low pressure versions of standard models.

Norgren Ltd.,  
 Cross Chancellor Street,  
 Leeds, LS6 2RT. England.  
 Telephone: +44 113 245 7587  
 Fax: +44 113 246 5735  
 Email: [salesenquiries@norgren.com](mailto:salesenquiries@norgren.com)

Our Ref: dsmanN 10/06  
 Controlled Doc. 2006-111a

*All instruments are tested on the Watson Smith Automatic Testing System and an individual test certificate is provided at no extra charge. Each unit is tested for linearity, hysteresis, total error, air consumption, response time and supply sensitivity.*

***Our policy is one of continuous research and development. We therefore reserve the right to amend without notice the specifications given in this document. Customers are responsible for ensuring that the product is used only for the purpose for which it is intended. In case of doubt Norgren will be pleased to advise.***